

22/00025/HOU & 22/00026/LIS- The Old Vicarage, Main Road, Hursley, SO21 2JW

Installation of an EV charge point for one vehicle and
landscape changes including pergola



Location Plan



Aerial Photograph

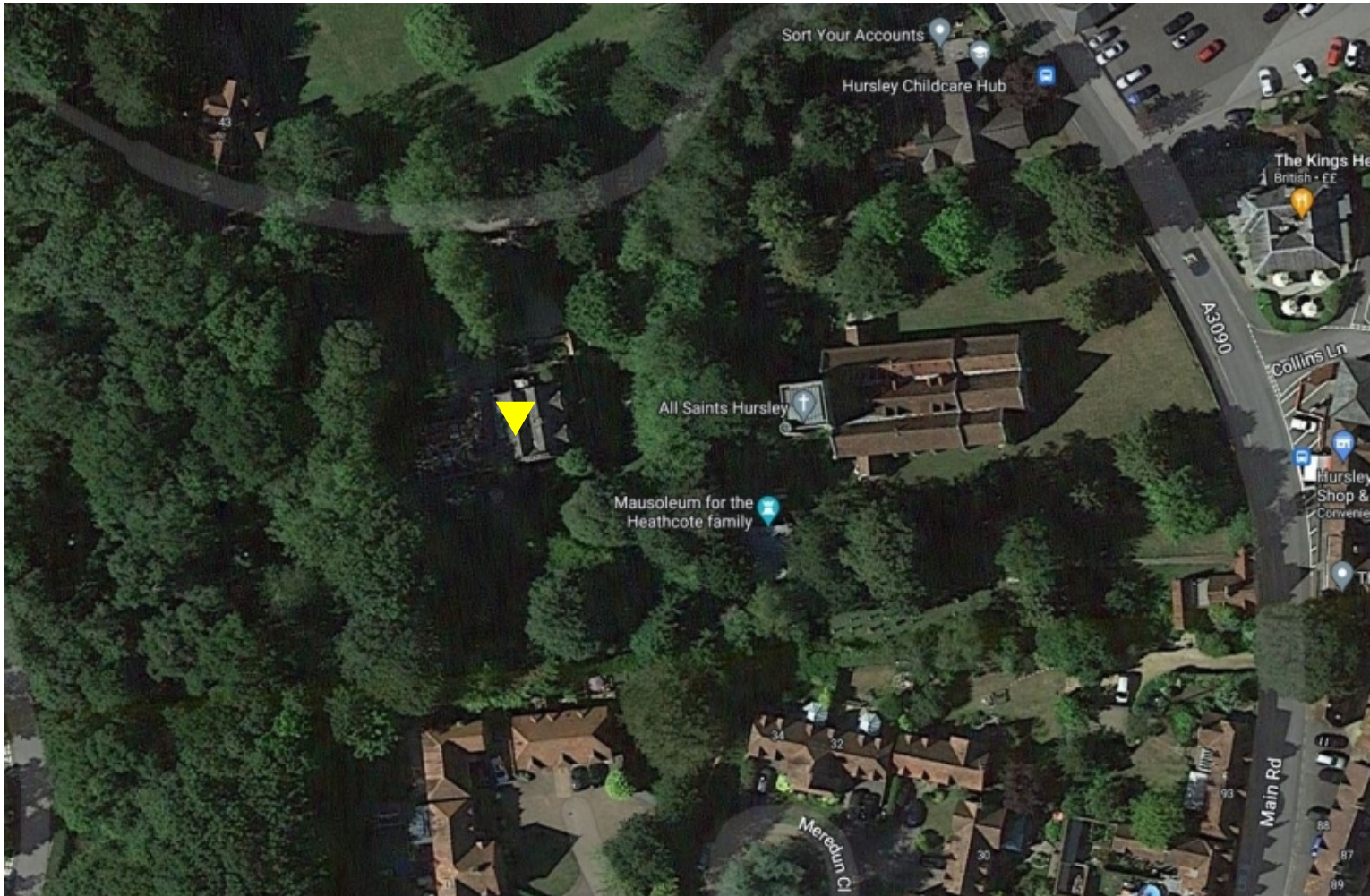

Floor Plan

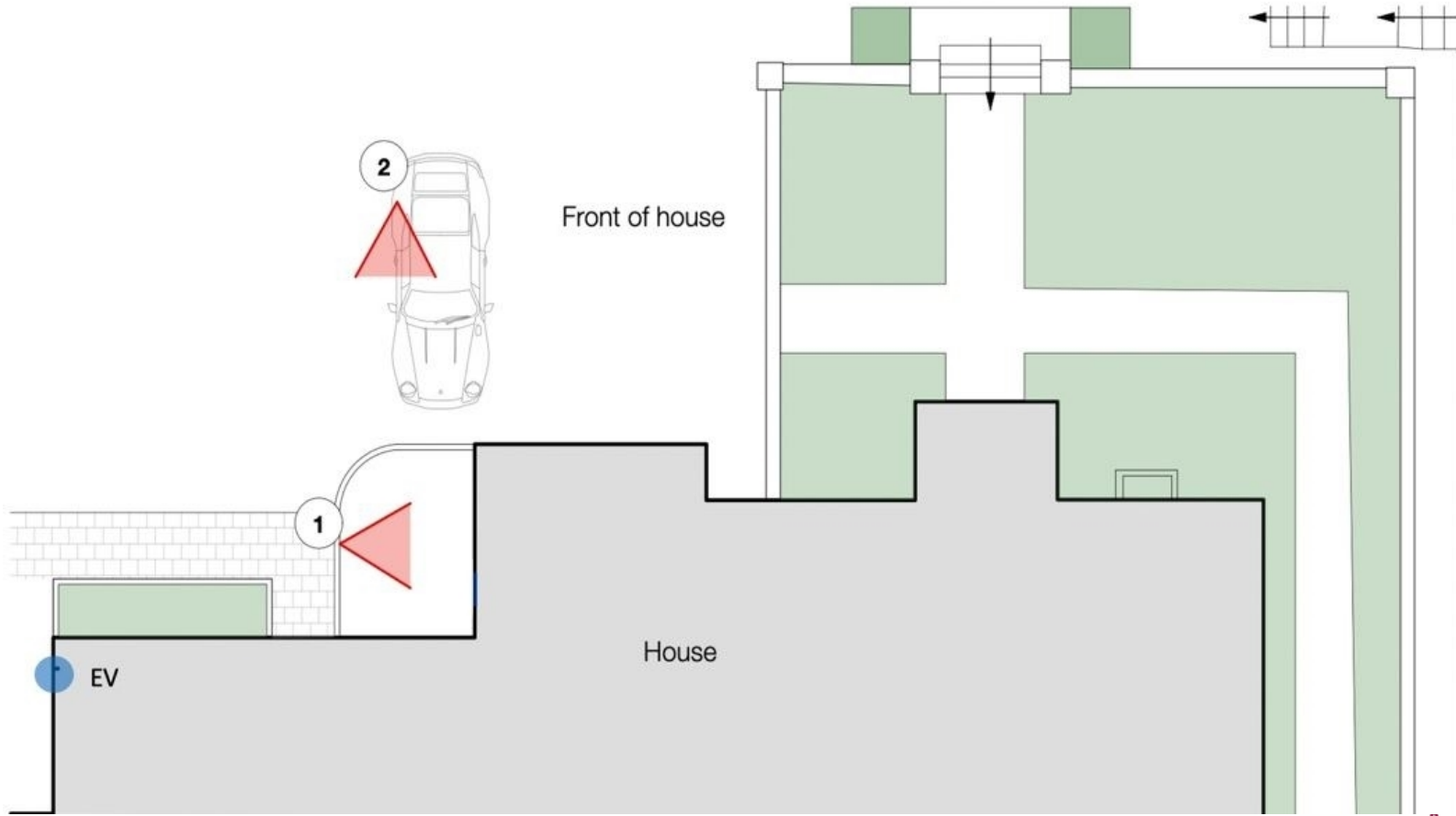

Photos of the Front Elevation



Charging Point in Situ



Landscape Plan

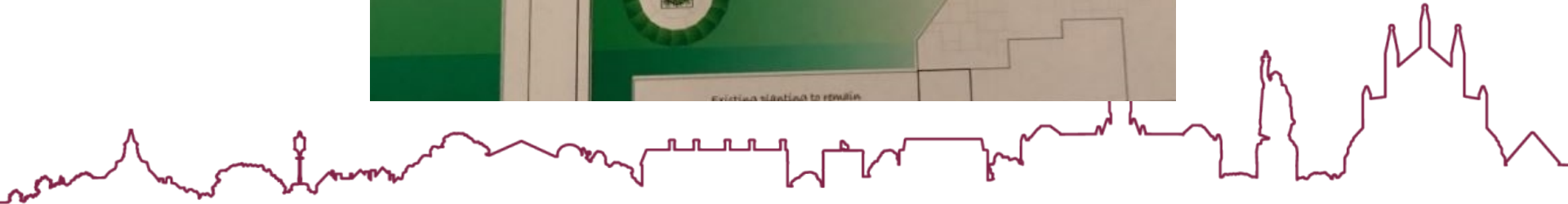
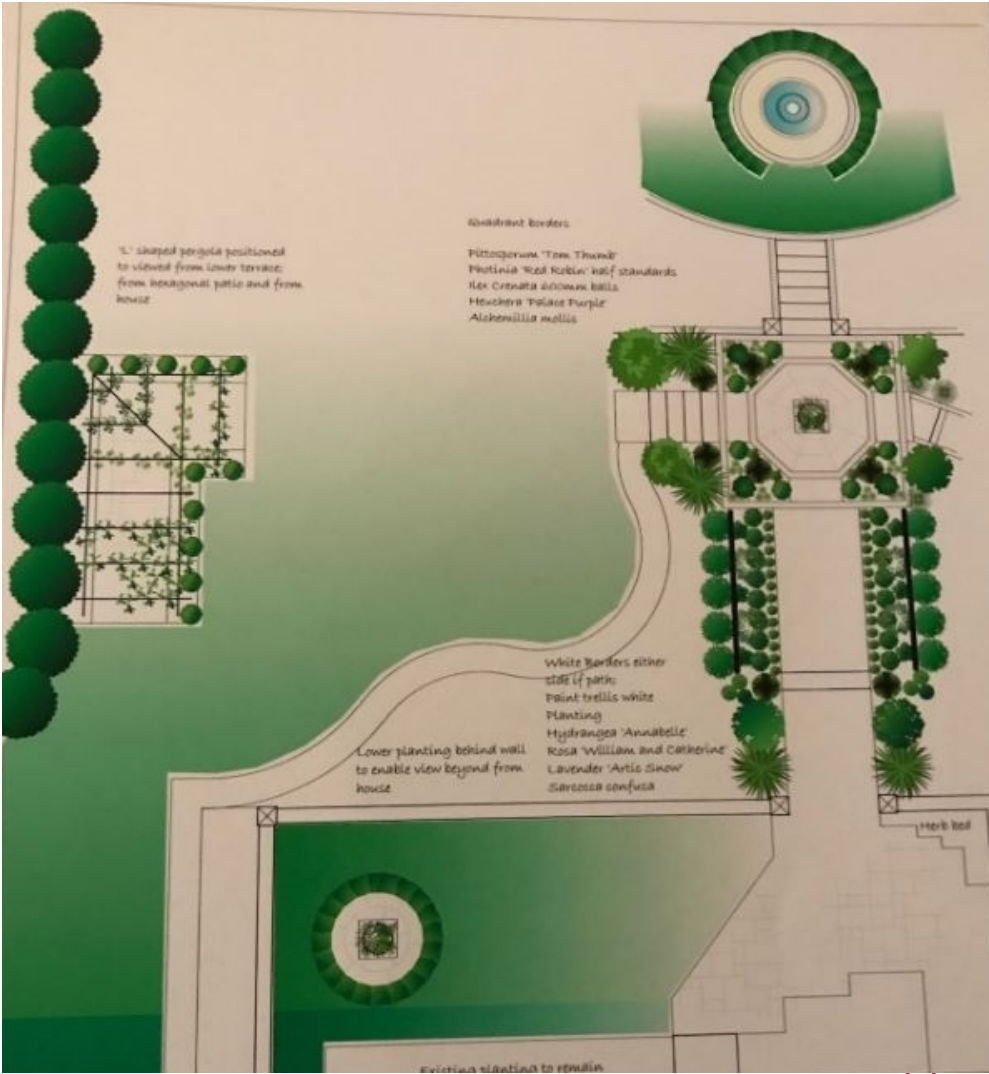

Pergola Plans & Indicative 3D

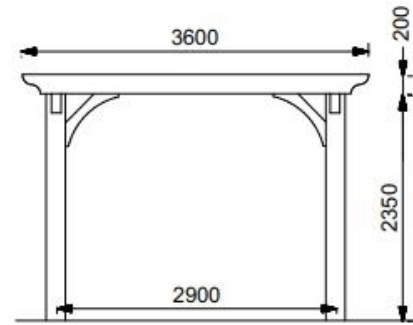
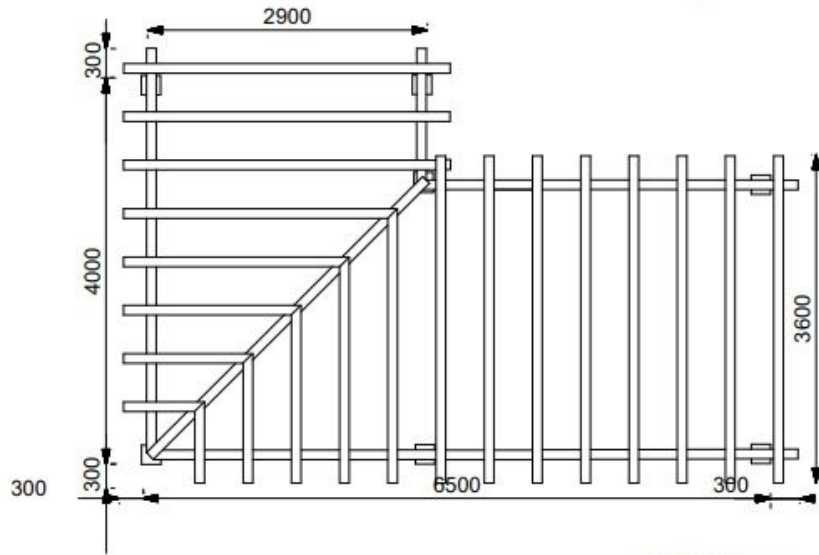

Photos looking at the landscaping to the rear



Photos looking towards the northern boundary with No. 42

